

REV.	ECN.NO.	MODIFY.CONTENT	DATE
A	JYS-EC150602	首次发行	2015/04/28

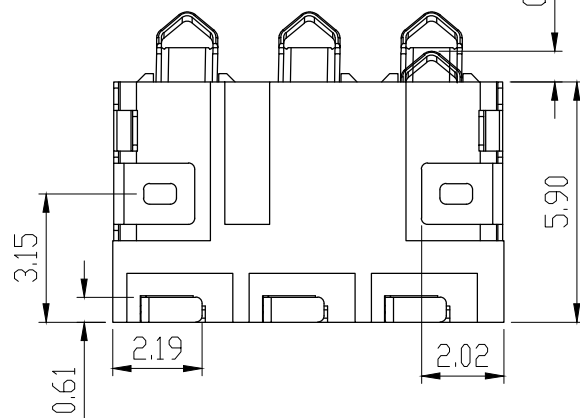
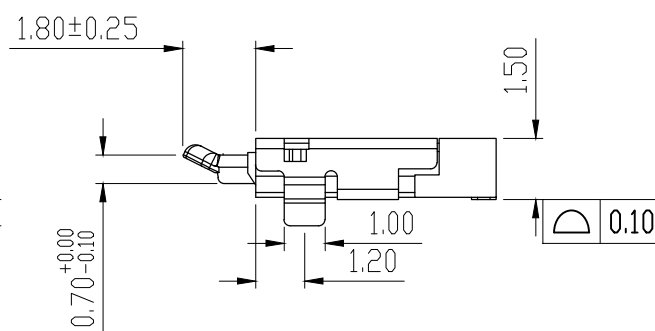
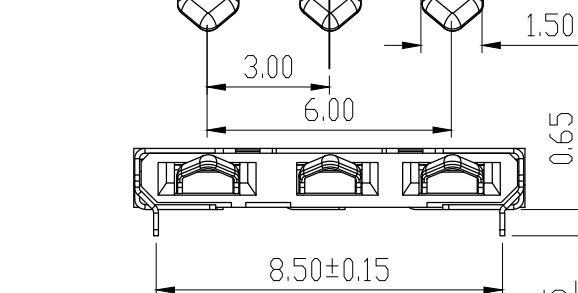
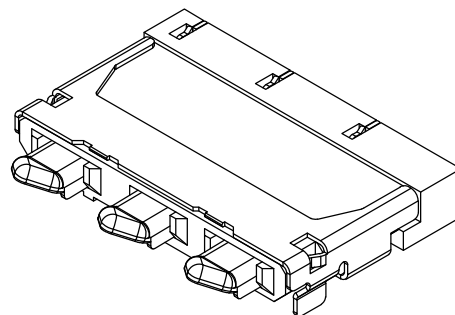
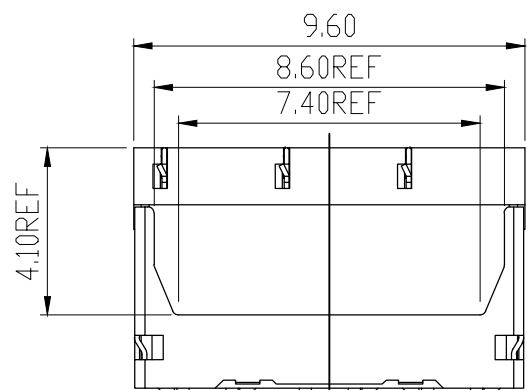

1. MATERIAL:

- 1.1. Housing: HI-TEMP Plastic, UL94V-0, black;
- 1.2. Terminal: Cobby alloy, T=0.12mm
- 1.3. Latch: Stainless steel T=0.12mm

2. FINISH:

- 2.1 Terminal: Plated Au on contact area, matte tin on the solder tails underplated nickel over all.
- 2.2 Latch: 120U" Min matte tin over nickel,

3. Electrical Performance:

- 3.1 Contact Resistance: 50mΩ Max;
- 3.2 Dielectric Withstanding Voltage: 350V AC rms for 1 minut;
- 3.3 Insulation Resistance: 1000 MΩ Min;

4. Mechanical Performance:

- 4.1 Durability: 5000 cycles;
- 4.2 Normal force: 60gf Min;

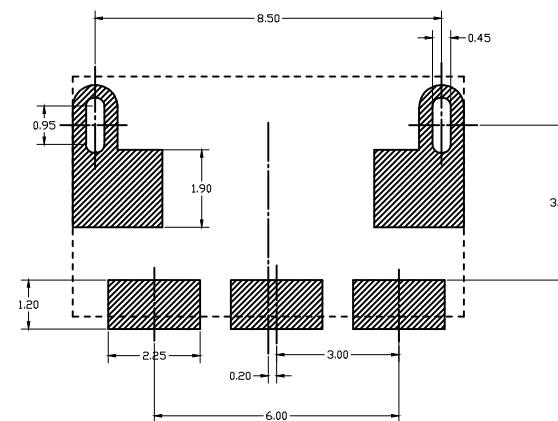

RECOMMENDED PCB LAYOUT

TOL:(±0.05)

Recommend PCB Layout

Tolerance: ±0.05

GENERAL TOLERANCE		图号	JYSA0623-001	设计		比例	1:1
X.±0.25	x.±5'	品名	3PIN 3.0PITCH BATTERY 1.5H端子上翘	审核		单位	mm
.X±0.20	.x'±2'			核准		视角	
.XX±0.15	.xx'±1'	料號	JYS-BY150-104	日期	2015/04/28	版本	A
.XXX±0.10	.xxx'±0.5'			杰宇森电子有限公司 JIE YU SEN ELECTRONIC CO., LTD.			
页号	1/1	模具编号					